

## Zusatz-Zahnrad-Pumpe

PVD-1B-32P, PVD-2B-36P, PVD-2B-40P, PVD-2B-42P

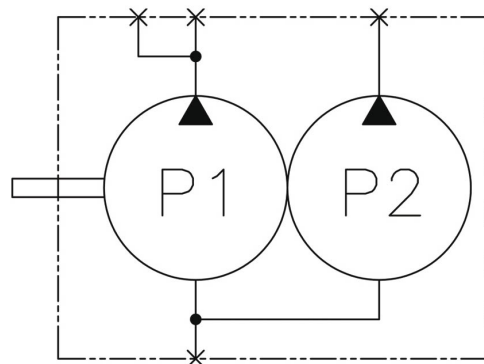
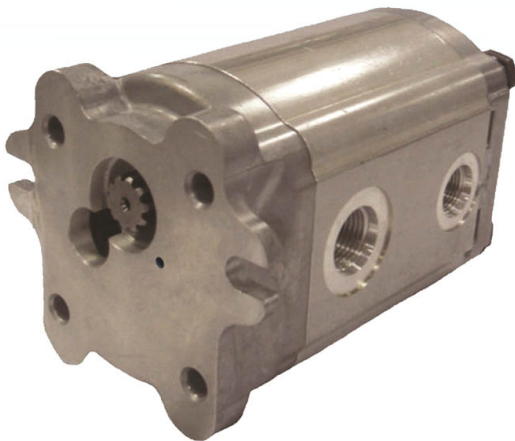

### Spezifikationen

Model		Fördermenge (cm <sup>3</sup> /U)	Max. Druck (bar)	Max. Drehzahl (U/min)
PVD-1B	P1	10.5	210	3200
	P2	4.5	40	
PVD-2B	P1	16.5	210	
	P2	4.5	40	

Masse (mm)

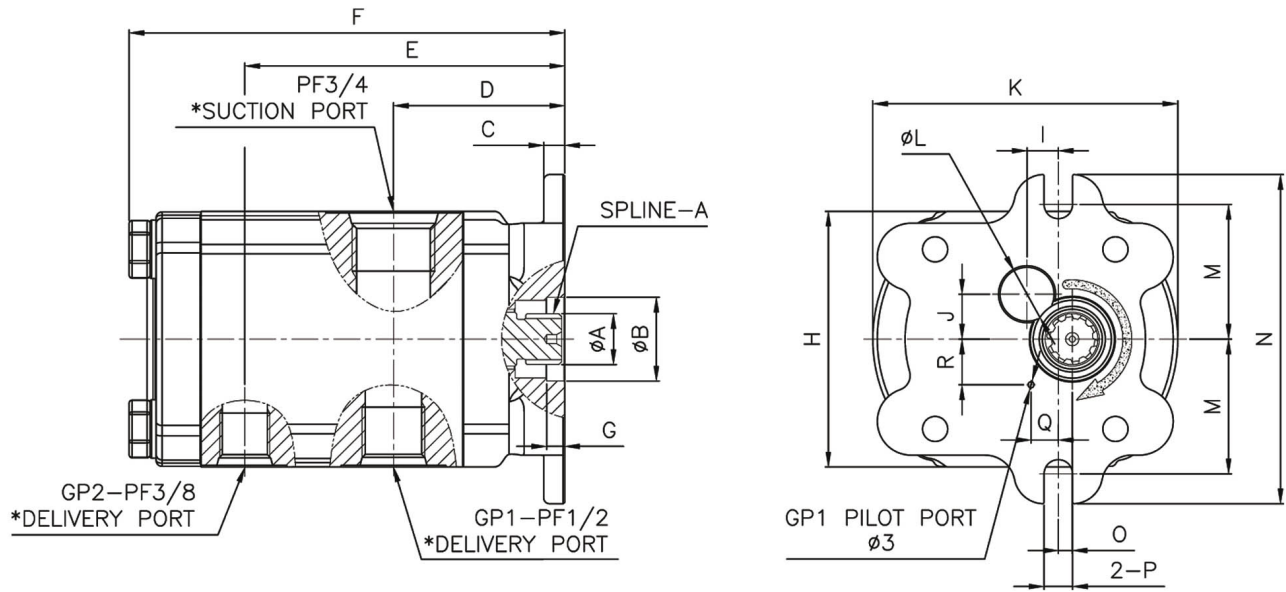

Model	A	B	C	D	E	F	G	H	I	J	K	L	M	N	O	P	Q	R	Spline
PVD-1B	17	28	7	59	96	135	6	85	10	15	102	18	45	110	4.7	9.5	9	15	Z10
PVD-2B					105	145													